

RI Series Relief Valve (ISO Mounting, Balanced Piston Type)

40 to 320 ℓ /min
35MPa

Features

- ① High pressure capacity balanced piston relief valve.
- ② Optimum pressure control for hydraulic circuit allows operation as a safety valve.
- ③ A vent port enables remote control of pressure and use of an unloading circuit.
- ④ ISO standard mounting service (see table below).

Specifications

Model No. Gasket Mounting	Nominal Diameter (Size)	Maximum Working Pressure MPa(kgf/cm ²)	Maximum Flow Rate ℓ /min	Pressure adjustment range MPa(kgf/cm ²)	Weight kg	Gasket Surface Dimensions
RI-G03-C-20	3/8	35{357} P, X Ports	40	0.15 to 3.5{1.5 to 35.7}	4.5	ISO 6264-AR-06-2-A
RI-G03-1-20 3 5	3/8		150	0.8 to 7{8.2 to 71.4} 3.5 to 25{35.7 to 255} 3.5 to 35{35.7 to 357}	4.5	
RI-G06-1-20 3 5	3/4		320	0.8 to 7{8.2 to 71.4} 3.5 to 25{35.7 to 255} 3.5 to 35{35.7 to 357}	5.6	ISO 6264-AS-08-2-A

● Handling

- ① To adjust pressure, loosen the lock nut and then rotate the handle clockwise (rightward) to increase pressure or counterclockwise (leftward) to decrease it.
- ② Make sure that tank port back pressure is no greater than 0.2MPa {2.0kgf/cm²}.
- ③ For use as a safety valve, use a pressure override that is higher than the required circuit pressure.
- ④ When using a remote control valve, connect piping to the relief valve port. Pipe capacity can cause vibration. Use of thick iron pipe with an

inside diameter of no more than 4mm and a connection length of no more than three meters is recommended.

- ⑤ The following are the bundled mounting bolts.

Model No.	Bolt Dimensions	Qty	Tightening Torque N·m(kgf·cm)
RI-G03-*-20	M12 × 50 ℓ	4	75 to 95 {765 to 970}
RI-G06-*-20	M16 × 60 ℓ	4	190 to 235 {1940 to 2400}

Note) For mounting bolts, use 12T or equivalent.

- ⑥ A small control flow rate can cause pressure instability. Use a control flow rate that is at least 8 ℓ /min.

Use a drain type relief valve in the case of a flow rate that is less than the minimum flow rate.

- ⑦ Use the following table for specification when a sub plate is required.

Model No.	Pipe Diameter	Weight kg	Applicable Pump Model
MRI-03-10	3/8	2.6	RI-G03
MRI-03X-10	1/2		
MRI-06-10	3/4	3.5	RI-G06
MRI-06X-10	1		

Understanding Model Numbers

RI - G 06 - 1 - 20

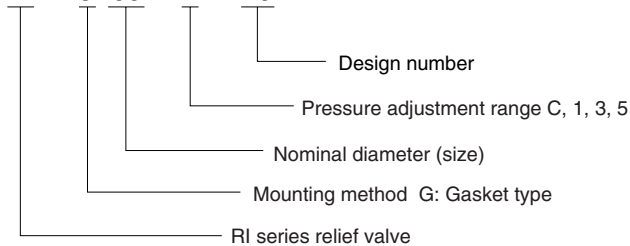

Installation Dimension Drawings

RI-G**-*-20

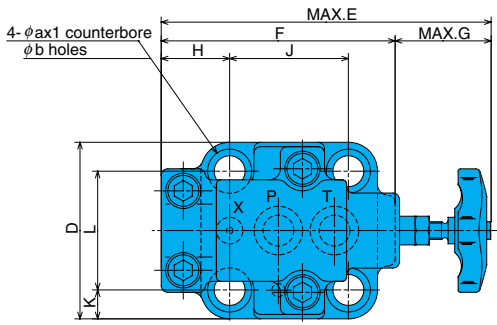

Model No.	A	B	C	D	E	F	G	H	J	K	L	a	b
RI-G03-*-20	132	78	32	80	149.5	106	43.5	31	53.8	13.1	53.8	20	14
RI-G06-*-20	137	83	36	100	158.5	119	39.5	37	66.7	15	70	26	17.5

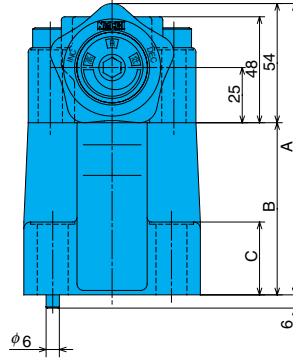
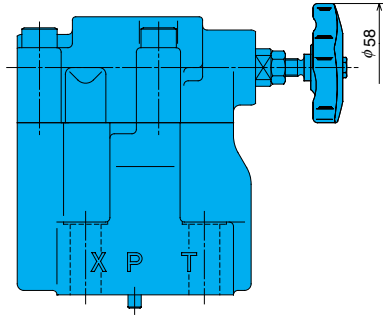

Sub Plate MRI-03*-10
(Maximum Operating Pressure: 25MPa)

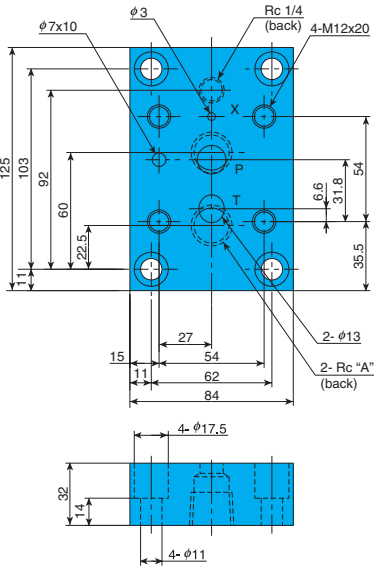

Sub Plate MRI-06*-10
(Maximum Operating Pressure: 25MPa)

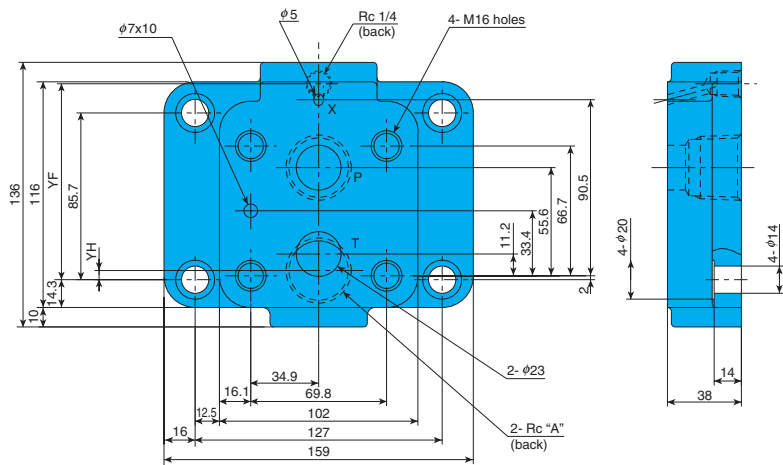

Attach a plug when the vent (X) port is not used.

Model No.	A
MRI-03-10	3/8
MRI-03X-10	1/2
MRI-06-10	3/4
MRI-06X-10	1

Model No.	YF	YH
MRI-06-10	92.5	13.2
MRI-06X-10	100.7	4.7

Performance Curves

Hydraulic Operating Fluid Viscosity 32mm²/s

Pressure - Flow Rate Characteristics

RI-G03-C-20

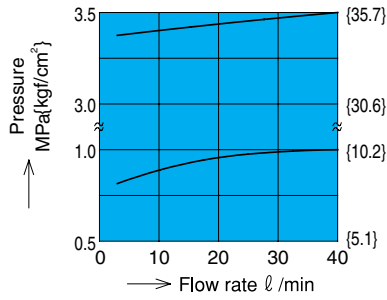

RI-G03-*-20

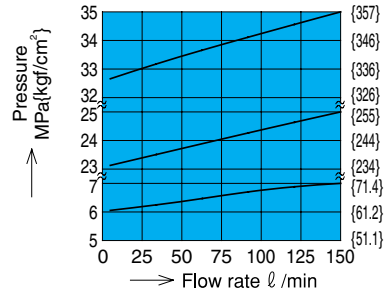

RI-G06-*-20

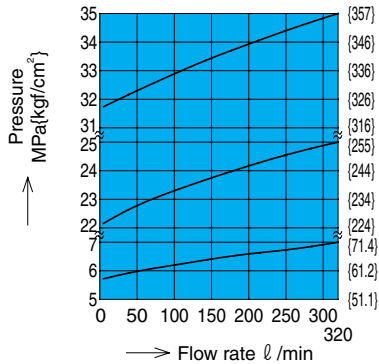

Note) The performance curves do not include T port back pressure.

Cross-sectional Drawing

RI-G**-*-20

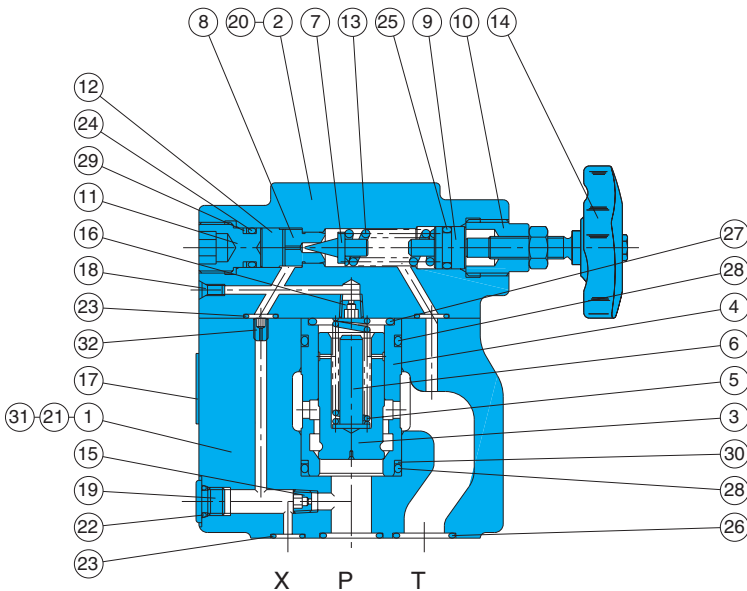

Part No.	Part Name	Part No.	Part Name
1	Body	17	Plate
2	Cover	18	Plug
3	Poppet	19	Plug
4	Sleeve	20	Screw
5	Spring	21	Pin
6	Spacer	22	O-ring
7	Poppet	23	O-ring
8	Seat	24	O-ring
9	Plunger	25	O-ring
10	Retainer	26	O-ring
11	Plug	27	O-ring
12	Collar	28	O-ring
13	Spring	29	Backup ring
14	Handle assy	30	Backup ring
15	Orifice	31	Screw
16	Orifice	32	Choke

Seal Part List (Kit Model Number REBS-***)

Part No.	Part Name	Nominal Diameter/Part Number		Q'ty
		G03	G06	
22	O-ring	1B-P8	1B-P8	1
23	O-ring	1B-P9	1B-P9	3
24	O-ring	1B-P10A	1B-P10A	1
25	O-ring	1A-P11	1A-P11	1
26	O-ring	1B-P18	1B-P28	2
27	O-ring	1B-G25	1B-P28	1
28	O-ring	1B-G30	1B-P32	2
29	Backup ring	T2-P10A	T2-P10A	1
30	Backup ring	T2-G30	T2-P32	1

Note) O-ring 1A/B-** refers to JIS B 2401-1A/1B-**. For the *** part of the kit number, specify the valve size (G03, G06).